

# BMW R1300GS '24- / R1300R '25- / R1300RS '25- / R1300RT '25-

## M O U N T I N G I N S T R U C T I O N S

REF 22307

ENGINE SPOILER



ID.	PIEZA/PART	DESCRIPCIÓN	DESCRIPTION	QTY.	REF.:
1		Lateral derecho quilla	Right side engine spoiler	1	22307JM3
2		Lateral izquierdo quilla	Left side engine spoiler	1	22307JM3
3		Base inferior quilla	Lower engine spoiler base	1	SOPOR3P4-B22310
4		Soporte superior	Upper support	1	SOPOR3P4-S22310
5		soporte inferior	Lower support	1	SOPOR3P4-I22310
6		Tornillo Allen M8X12 ISO7380	M8X12 ISO7380 allen screw	2	TORNI-I7380-550
7		Arandela de nylon M8	M8 nylon washer	2	ARAND-----799
8		Tornillo allen M6x16 Ø14 ISO 7380	M6x16 Ø14 ISO 7380 Allen screw	4	TORNI-I7380-403
9		Arandela de nylon M6	M6 nylon washer	4	ARANDEPNVCN0246
10		Tapon M6 ISO 7380	M6 ISO 7380 screw cap	4	TAPON-----86
11		Tornillo M8x16 DIN912	M8X16 DIN912 screw	2	TORNI-D912--623
12		Tornillo allen M5x12 Ø11 ISO 7380	M5x12 Ø11 ISO 7380 Allen screw	4	TORNI-AI-----520
13		Tuerca de clip M6 (NEGRA)	M6 clip nut	4	TUERCA-TRT-M6--
14		Amortiguador antivibratorio silentblock Ø30x30 (M8x20, int M8x8)	Ø30x30 (M8x20, int M8x8) Anti-vibration damper silentblock	2	SILENTBLOCK-542
15		Tornillo M8x12 DIN912	M8x12 DIN912 Allen screw	2	TORNI-D912--742
16		Arandela de contacto M8	M8 contact washer	4	ARAND-----803

# BMW R1300GS '24- / R1300R '25- / R1300RS '25- / R1300RT '25-

INSTRUCCIONES DE MONTAJE - MOUNTING INSTRUCTIONS - MONTAGEANLEITUNG

**1**

DISASSEMBLY  
DESMONTAJE

**FOR THE INSTALLATION OF THE PUIG ENGINE SPOILER IT'S NECESSARY DISASSEMBLY ORIGINAL ENGINE SPOILER OR OIL CARTER GUARD WITH ORIGINAL SUPPORTS. THIS IS AN EXEMPLE :**

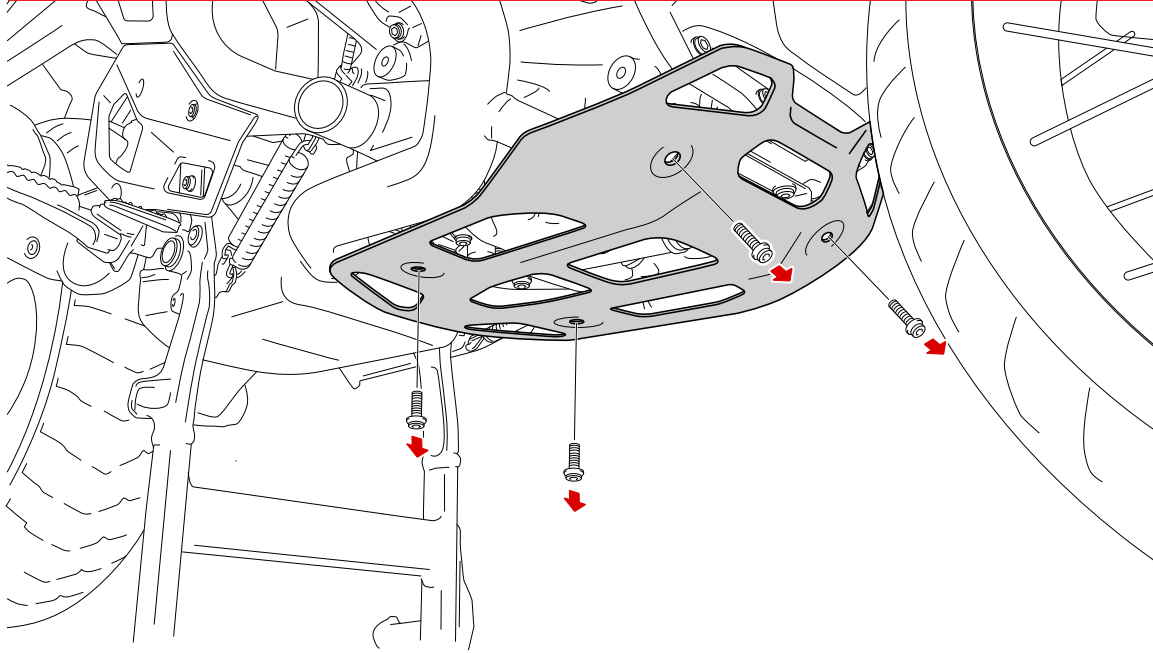

**2**

DISASSEMBLY  
DESMONTAJE

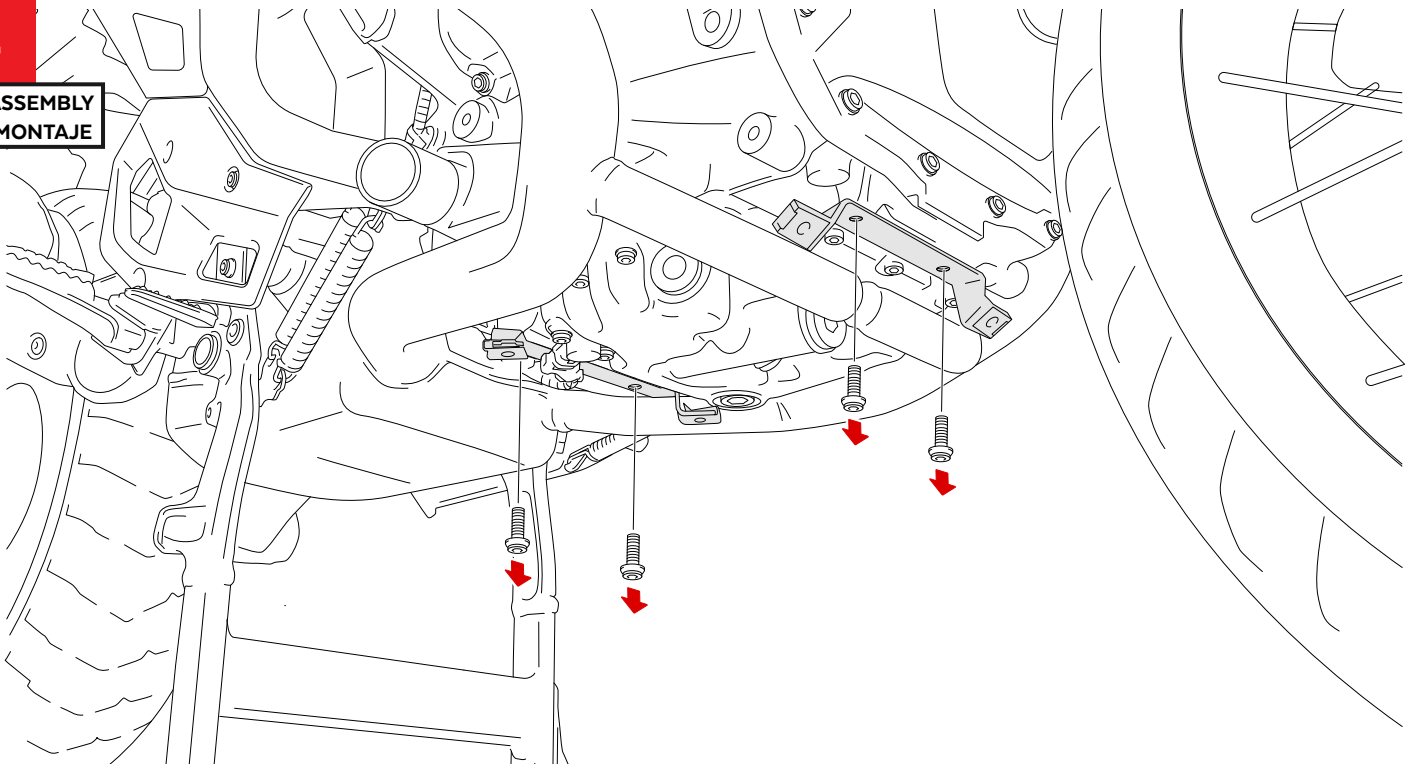

# BMW R1300GS '24- / R1300R '25- / R1300RS '25- / R1300RT '25-

INSTRUCCIONES DE MONTAJE - MOUNTING INSTRUCTIONS - MONTAGEANLEITUNG

**3**

ASSEMBLY  
MONTAJE

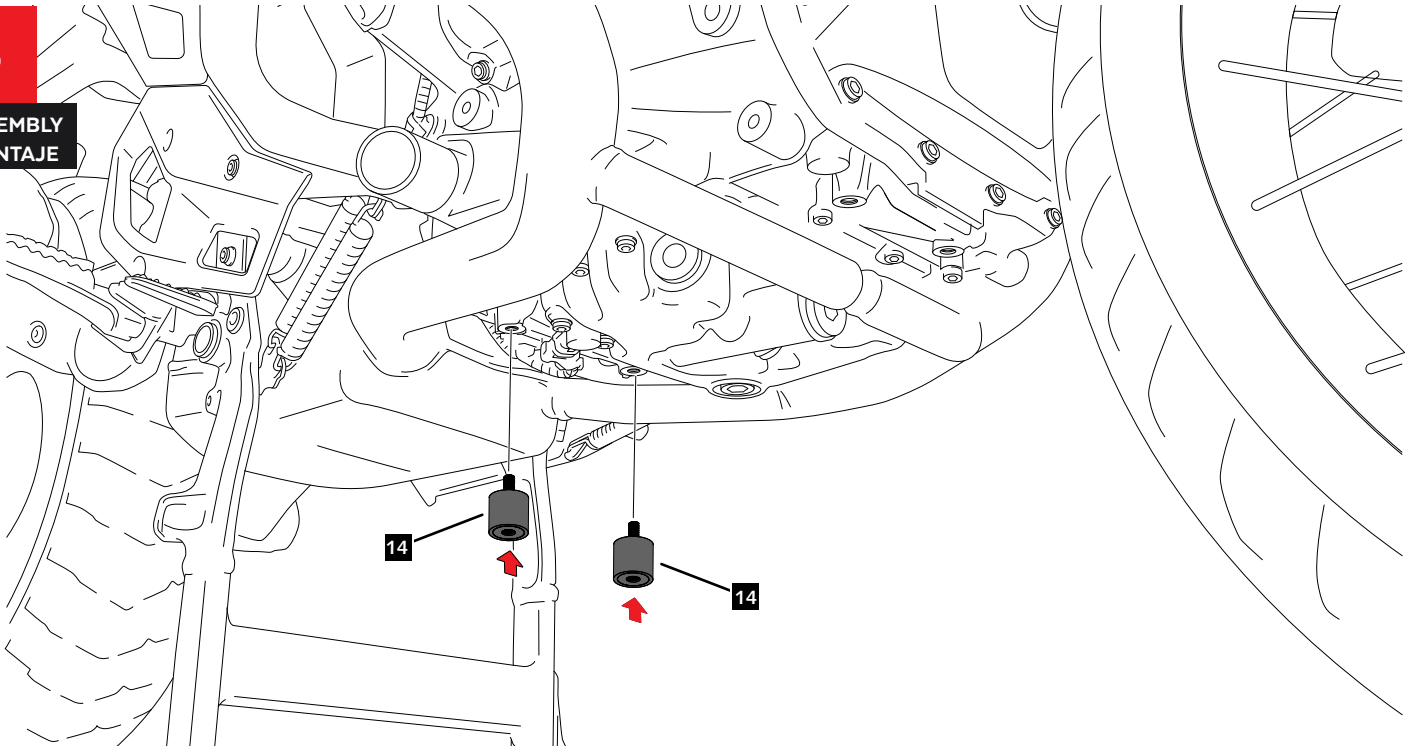

**4**

ASSEMBLY  
MONTAJE

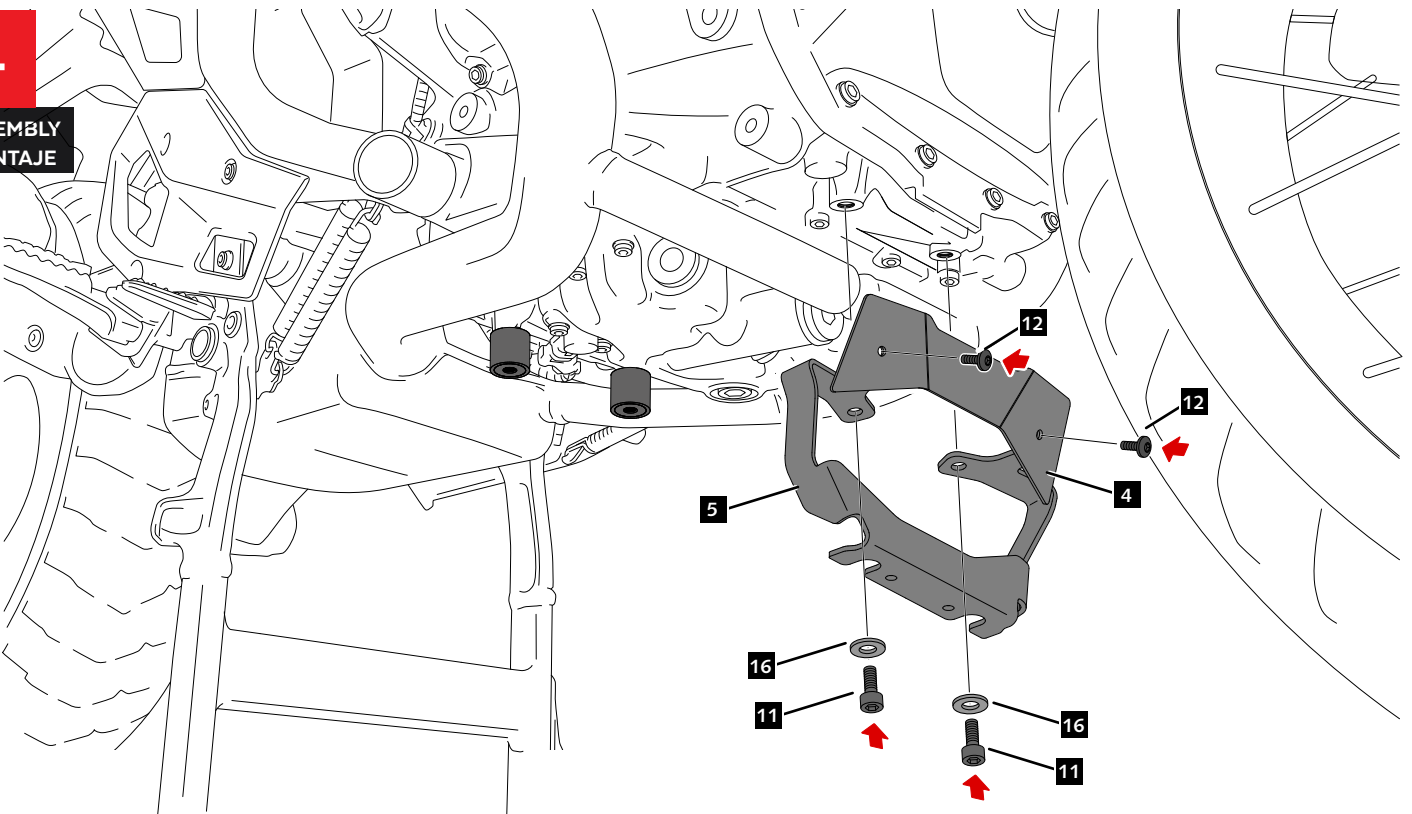

# BMW R1300GS '24- / R1300R '25- / R1300RS '25- / R1300RT '25-

INSTRUCCIONES DE MONTAJE - MOUNTING INSTRUCTIONS - MONTAGEANLEITUNG

**5**

ASSEMBLY  
MONTAJE

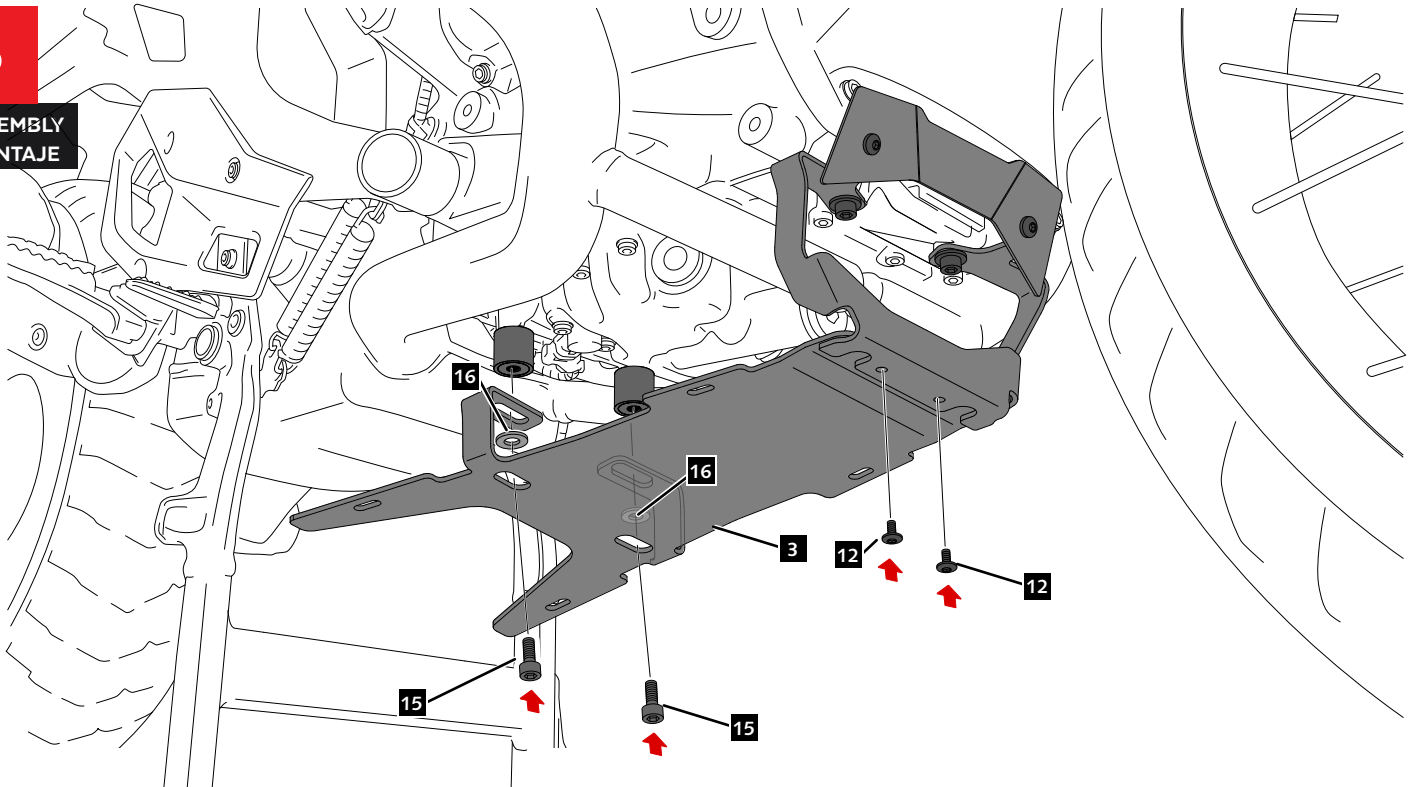

**6**

ASSEMBLY  
MONTAJE

Se muestra el montaje del lado derecho a modo de ejemplo, realizar los mismos pasos para el montaje del lado izquierdo.  
The right side assembly is shown as an example, so the same steps can be performed for the left side assembly.

